

CHEMICAL BONDING

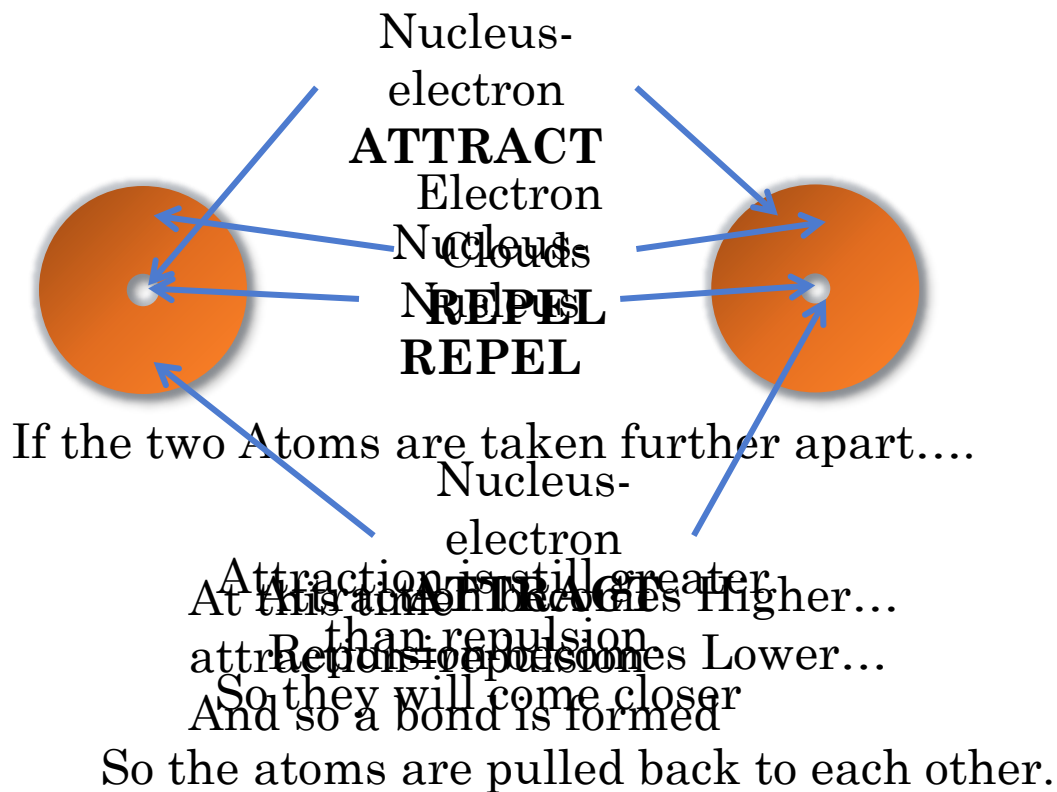

How bonds are formed? Orbital Overlap



Bond Length and Energy

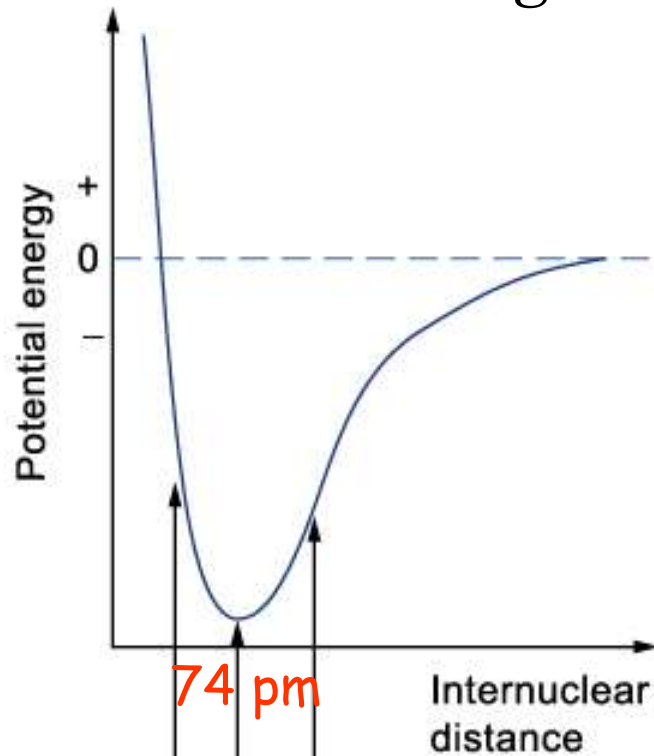

When H - H distance = 74 pm,

Repulsion = Attraction

⇒ strongest bond

⇒ optimal overlap

⇒ lowest energy

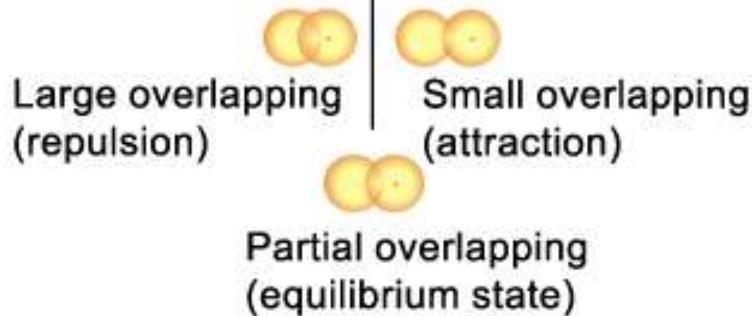

Bond Length and Energy

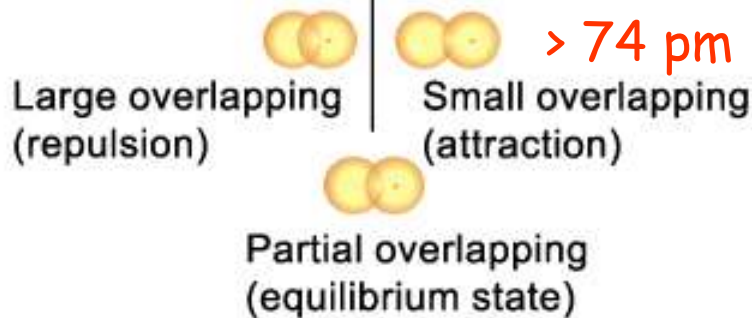
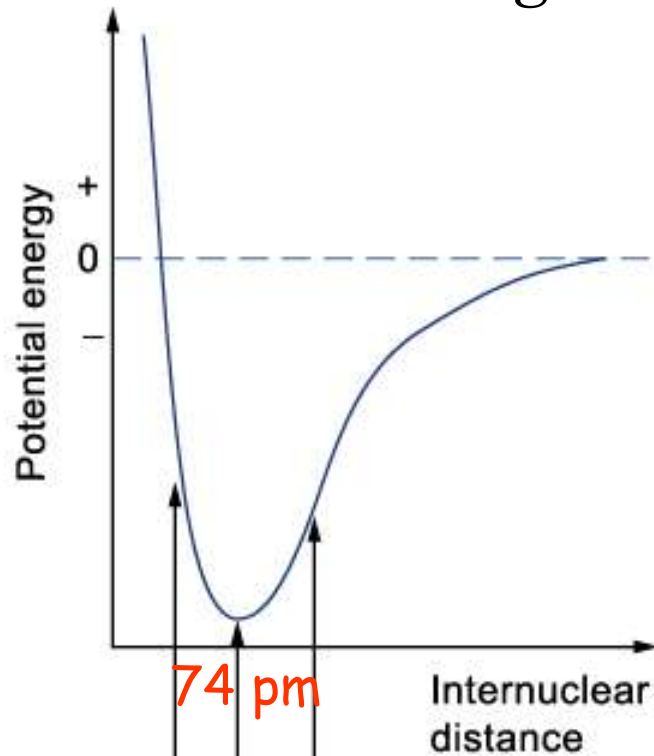

At H - H distance > 74 pm,
Repulsion $<$ Attraction
 \Rightarrow weaker bond
 \Rightarrow too little overlap
 \Rightarrow atoms come closer



Bond Length and Energy

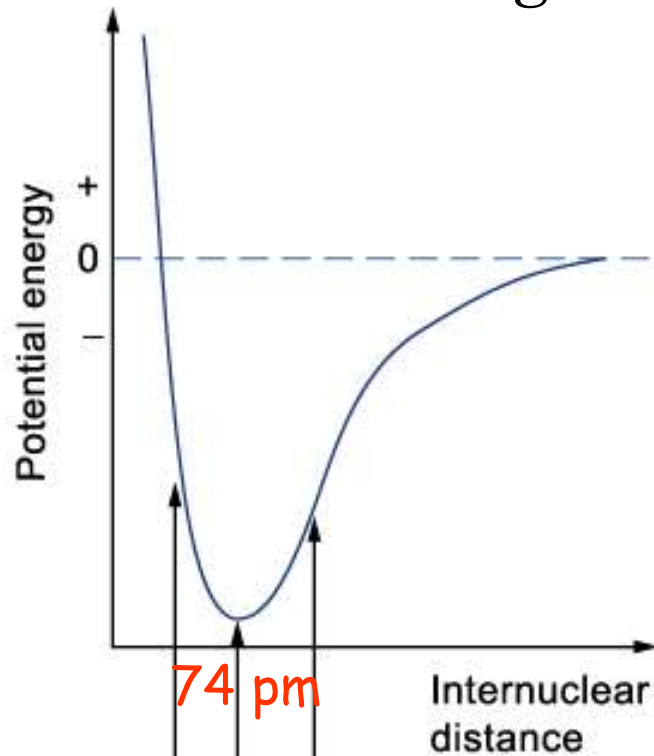

At H - H distance < 74 pm,
Repulsion $>$ Attraction
 \Rightarrow weaker bond
 \Rightarrow too much overlap
 \Rightarrow atoms get further apart

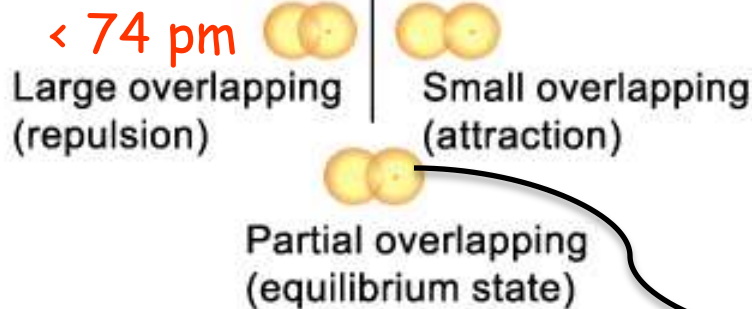

Bond Length of H₂=74 pm



Types of Bonds

Sigma bond formation

S-S overlapping



S-P overlapping



P-P overlapping

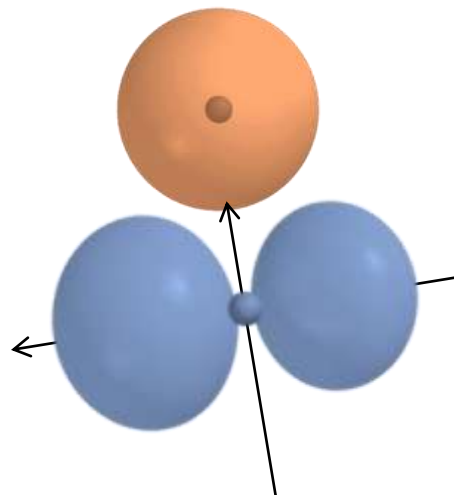
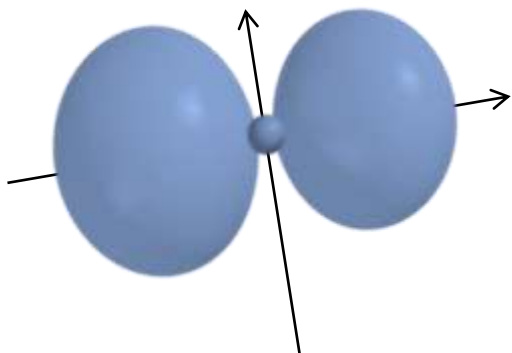

H - H

H - F

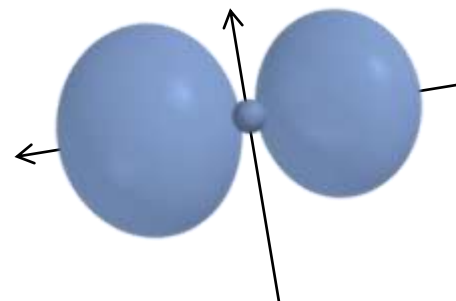

F - F



Types of Bonds

Pi bond formation

P-P Overlapping



This orbital overlap can explain the bond formation in H_2 , Cl_2 , $H - Cl$ etc.

But then some cases were found where this theory cannot explain the formation of some of the compounds.

For example, CH_4 molecule has all bonds of equal length and energy. How this possible since orbitals have different shapes.

So we needed something to explain this fact and that is called **hybridization**. It is the process of intermixing of orbitals to form new orbitals(called hybrid orbitals).



Hybridization

sp hybridization

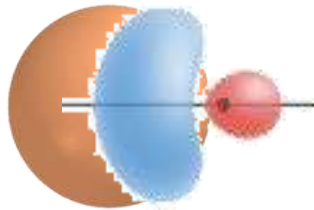

s-orbital

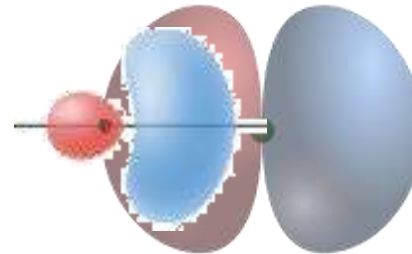

p-orbital

They mix with each other

And forms two sp orbitals
oriented at angle of 180°

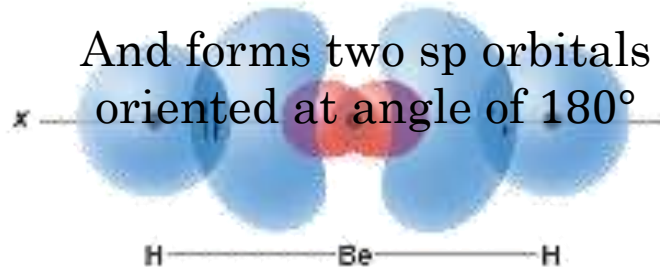

For example, BeH_2 structure is



Formation of BeCl_2 molecule

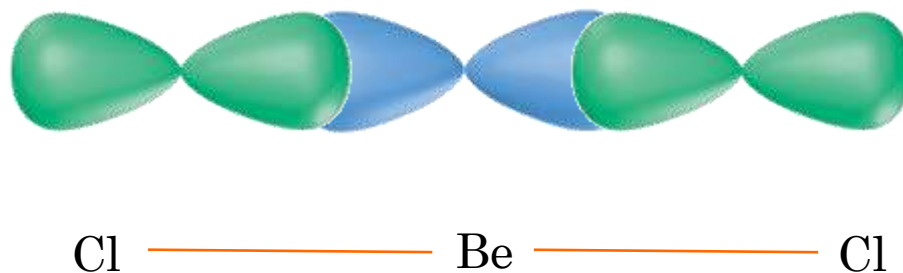
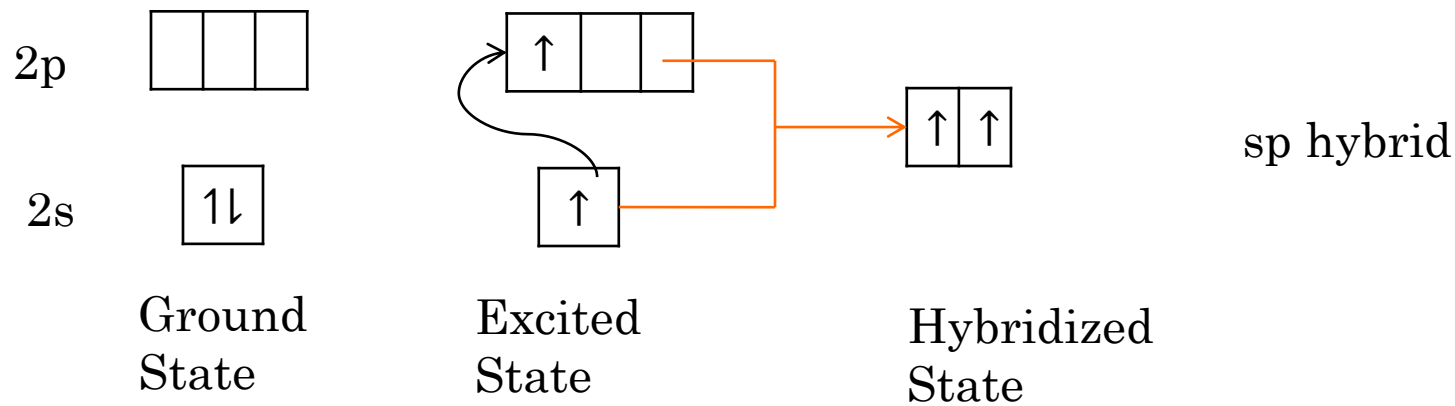

sp² hybridization



s-orbital

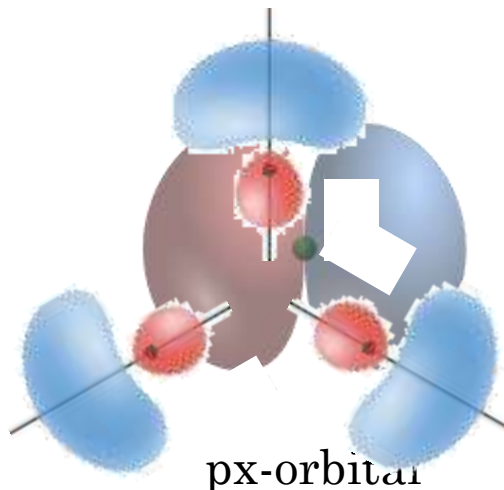

px-orbital

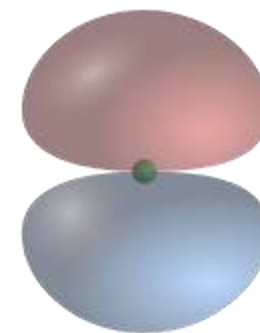

py-orbital

They mix with each other
And forms three sp²
orbitals oriented at angle of
120°



Formation of BF_3 molecule

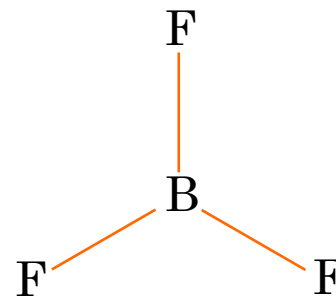
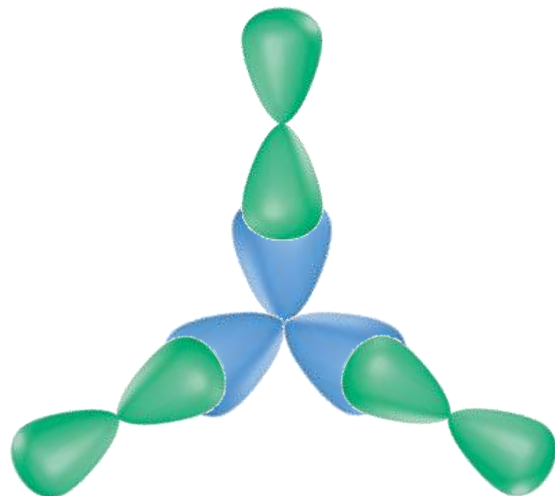
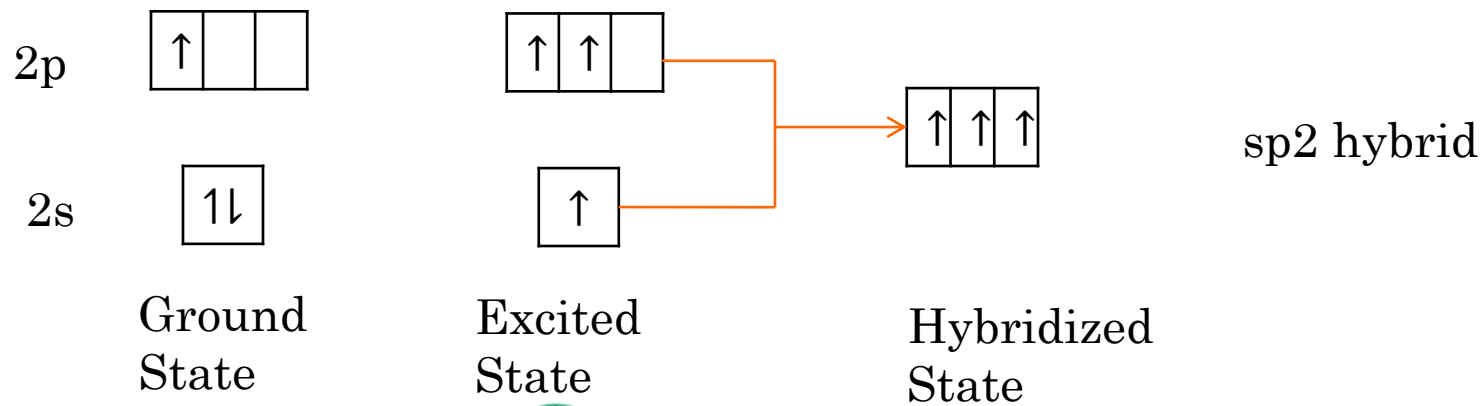

sp³ hybridization

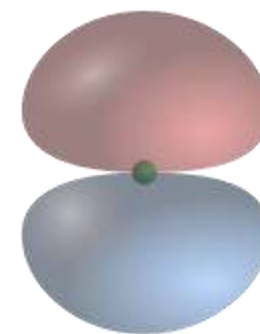
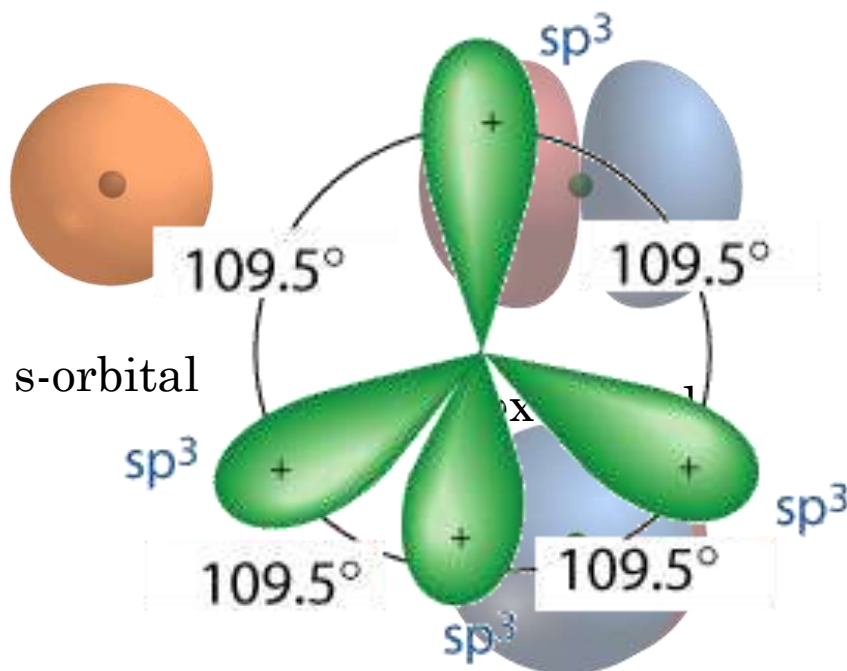

py-orbital

They mix with each other
 And forms four sp³ orbitals
 oriented at angle of 109.5°



Formation of CH₄ molecule

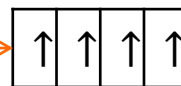
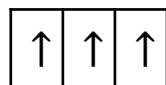
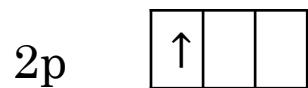

sp³ hybrid



Ground State

Excited State

Hybridized State

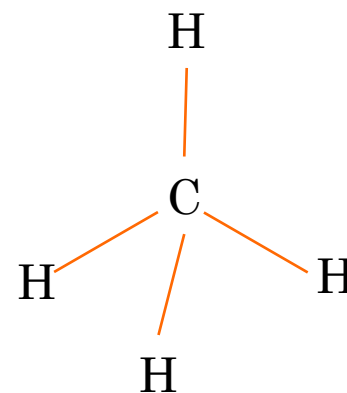
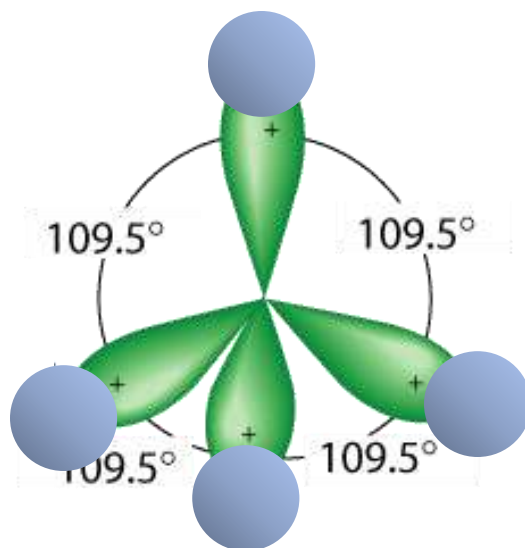

sp³d hybridization



s-orbital

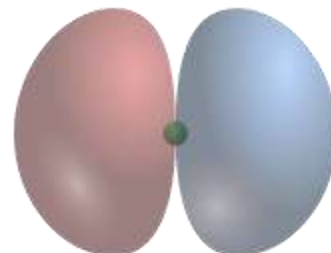

px-orbital

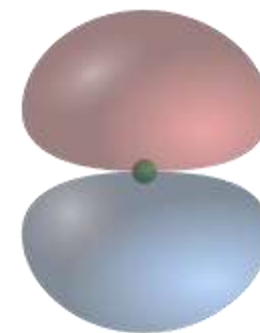

py-orbital



pz-orbital

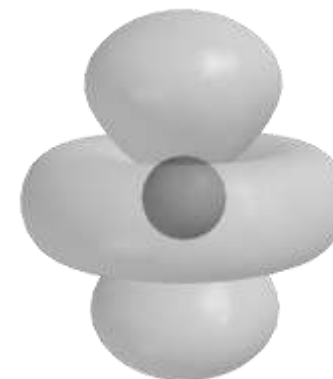

dz²-orbital

They mix with each other
And forms five sp³d orbitals



For example, structure of PF_5 is

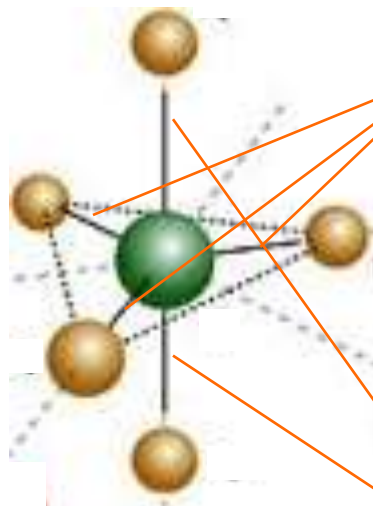

Three bonds are in the same plane at an angle of 120°

The other two bonds are perpendicular to the plane



Formation of PCl_5 molecule

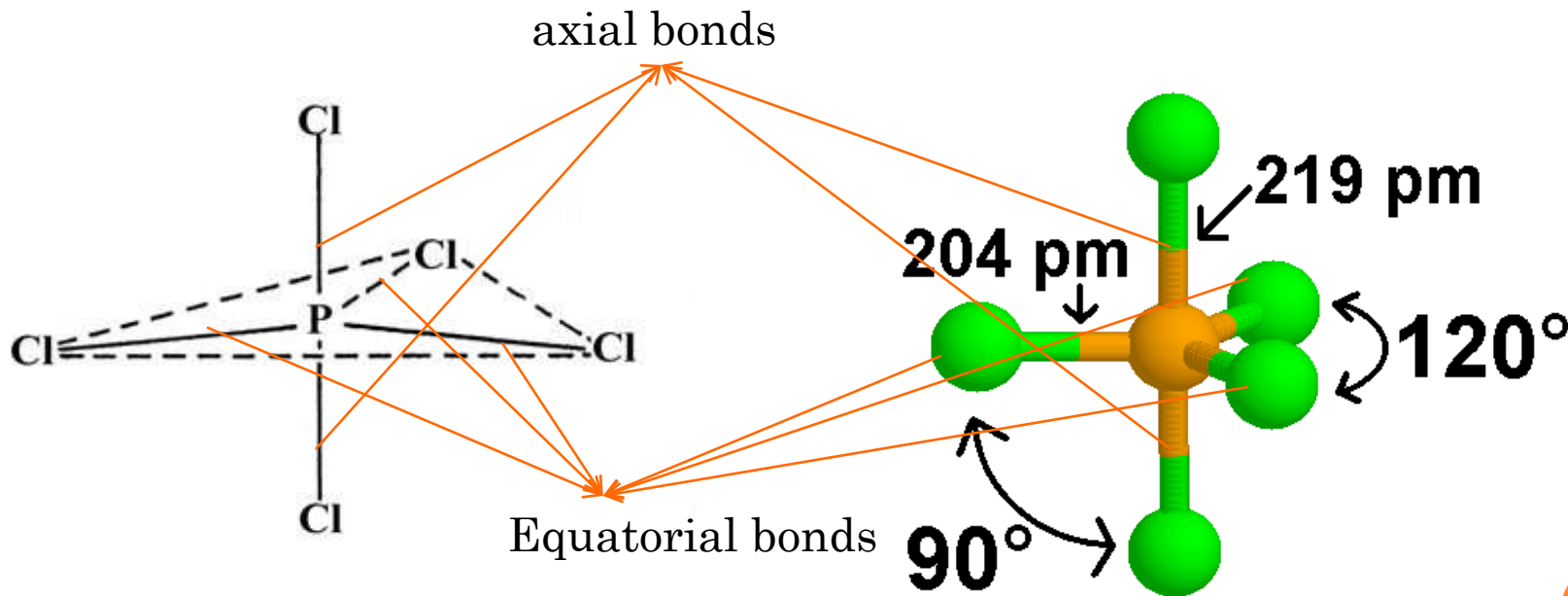
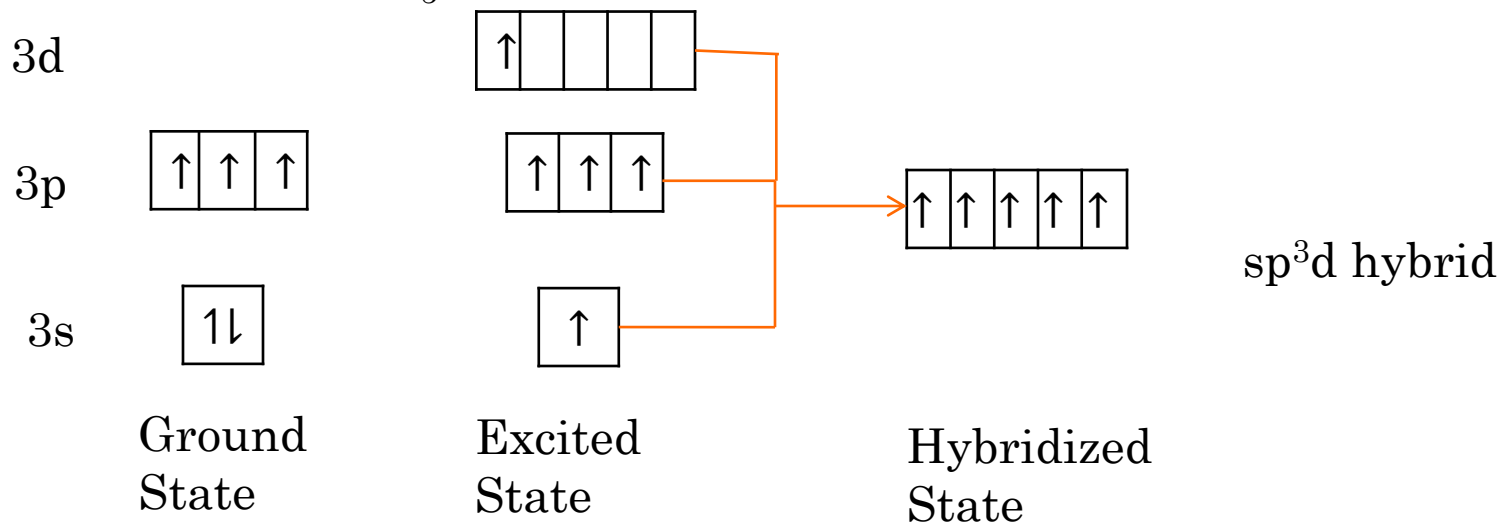

Equatorial bonds are smaller than axial bonds



Formation of SF₆ molecule, sp³d² hybridization

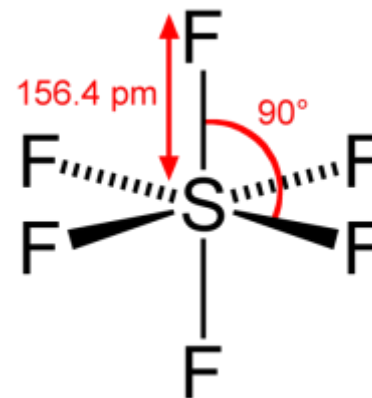
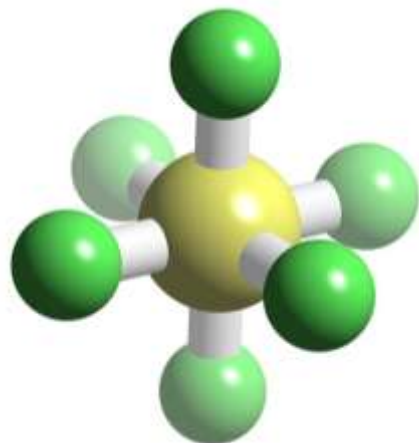
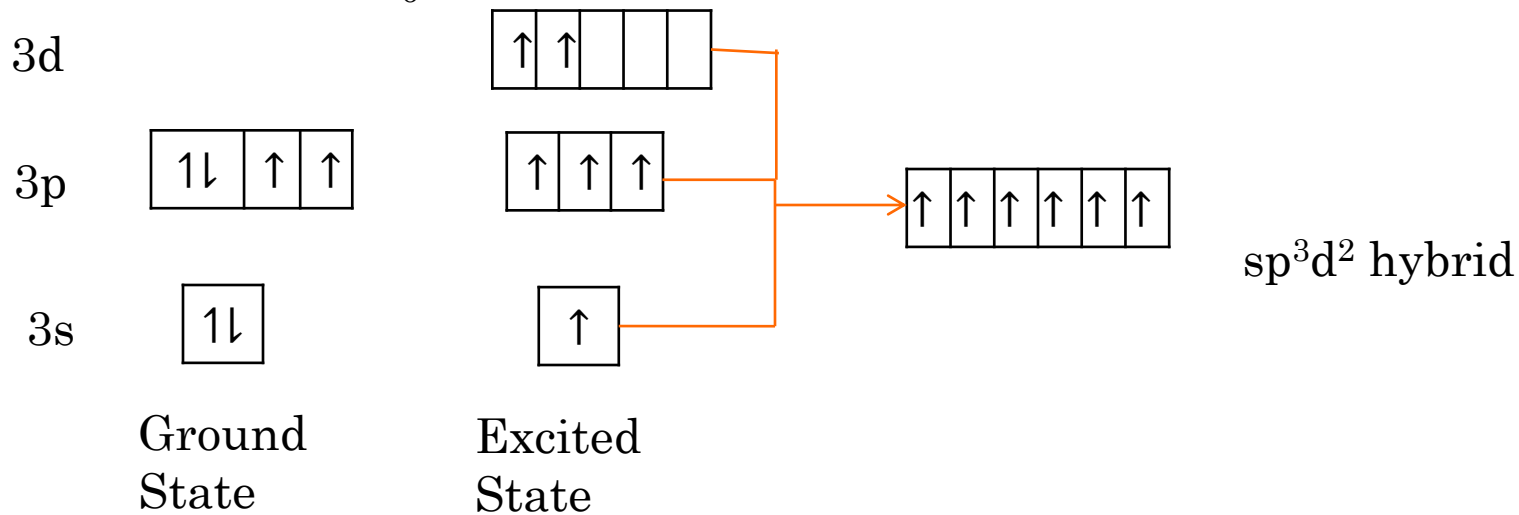

All the six bonds are equal and are oriented at 90° with each other



sp^3d^3 hybridization; Formation of IF_7 molecule

$1s+3p+3d$ orbitals combine to form 7 sp^3d^3 orbitals

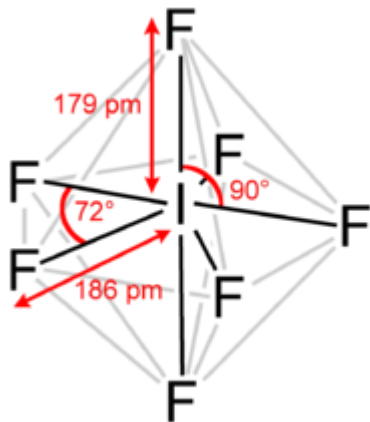

seven sp^3d^3 orbitals

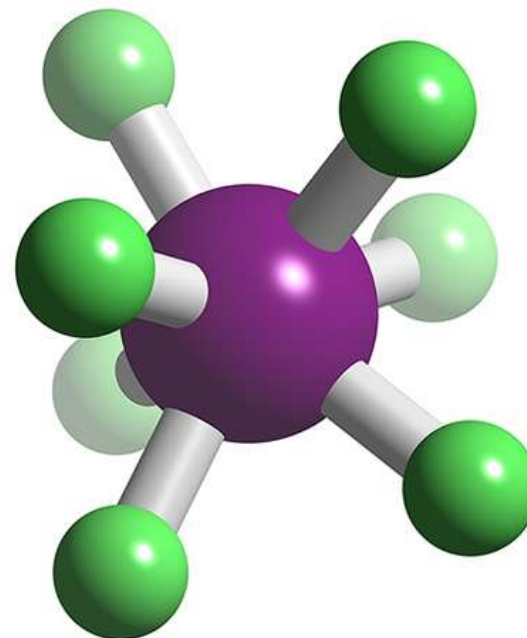

Ques: Explain the formation of NH_3 molecule

Formation of NH_3 molecule

